



Phase-Shift Oscillator

By: Walter Banzhaf
P.E. Professor of Engineering Technology
University of Hartford
Ward College of Technology

Abstract:

The ability to observe two channels simultaneously makes it possible to see phase relationships between two voltages. Thus, we can tell if an amplifier has a non-inverting gain or an inverting gain by triggering on the input sinusoid, and observing the input on channel 1 and the output simultaneously on channel 2. While two channels are better than one channel, the ability to observe four channels at the same time, and to see precise phase information, makes a four-channel digitizing oscilloscope a powerful tool for learning. In this exercise you will observe four key voltages in the phase-shift network of an RC Phase-Shift Oscillator.

Equipment:

- 1) Agilent 54601B - Series Oscilloscope

Circuit Diagram:

In the diagram of the phase-shift oscillator below, the output of the op-amp (node 1) will be the reference, and is connected to channel 1. The trigger source will be channel 1 (selected on the oscilloscope), and channels 2, 3 and 4 will be connected to circuit points 2, 3 and 4, respectively. In this way, the progressive phase shift (approximately $+60^\circ$), and the amplitude decrease from one point to the next, can be seen. Refer to Figure 1. In order for oscillation occur, two conditions must be satisfied:

- 1) the phase shift of the CR-CR-CR phase shift network (180° at one and only one frequency) plus the phase shift of the amplifier itself (180°) must equal 360° , AND
- 2) the op-amp must provide an inverting voltage gain of 29 V/V, to overcome the loss of the CR-CR-CR feedback network.

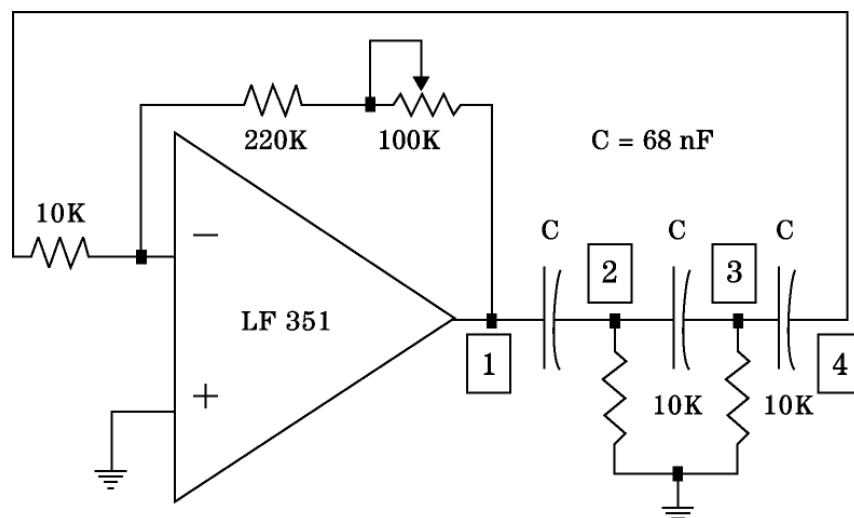



Procedure A - Observing 4 Voltages In Steady-state:

- 1) Return the oscilloscope to its default settings by pressing the SETUP hardkey, and then the DEFAULT SETUP softkey.
- 2) Connect channel 1 to point 1 in the circuit above with a 10X probe. Connect channel 2 to point 2 with a 10X probe. Connect channel 3 to point 3 with a 10X probe, and connect channel 4 to point 4 with a 1X cable.
- 3) Turn on the power switch on the op-amp designer board, set the 100K ohm potentiometer for maximum resistance (this provides maximum gain and ensures that oscillation will occur) and press the **AUTOSCALE** hardkey. Then press the **SOURCE** hardkey and press the **1** softkey, to select channel 1 as the trigger source. Adjust the volts/division and position controls for channels 1 and 2 on the front panel controls for a display that makes sense to you. For channels 3 and 4, the position controls are on the front panel, while the volts/division are set by softkeys that appear when the hardkey buttons for channel 3 or 4 are pressed. **For all four channels, be sure to make the probe setting correct (1X or 10X, as appropriate) by using the PROBE softkey for that channel (press 1,2, 3 or 4 to select that channel, and then press the PROBE softkey as needed to toggle between a divide by 1 or 10 or 100 probe).**
- 4) Reduce the value of the 100K ohm potentiometer so that the node 1 voltage is an undistorted sinusoid. Notice that the phase of the voltage at each point leads the prior node by about 60°. Measure the peak-peak voltage at each point, and the phase of each voltage (with the voltage at node 1 as the 0° reference) and record it in the table below. You can use the time cursors (Measure **CURSORS** hardkey) to measure the time interval between zero crossings, and convert the time intervals into phase angles as follows:

$$phase\ shift = \frac{\Delta\ time}{period} * 360^\circ$$

| Node No. | Peak –Peak voltage | Phase of voltage |
|----------|--------------------|---------------------------------|
| 1 | | 0 degrees (the reference point) |
| 2 | | |
| 3 | | |
| 4 | | |

Procedure B - Seeing The Start-up Of The Oscillator In Single-sweep Mode:

- 1) Refer to Figure 2, attached, showing the oscilloscope hardcopy of the start-up of the oscillator. Notice that all the necessary data are there, needed to set the controls of the oscilloscope to get it ready for capturing the start-up of the RC phase-shift oscillator.
- 2) Key things you must do in order to capture this transient event include:
 - a) Turn off the power to the oscillator. Make the resistance of the 100K Ω gain potentiometer maximum (to ensure enough there is enough gain for oscillation to begin).



b) Be sure to adjust the following oscilloscope settings (see Figure 2) with power still off: channel 1 probe = 10, channel 1 V/div = 5, trigger mode = single and source = 1, trigger level (or approximately equal to) +1V, main time/div = 50 ms.

c) Turn power ON, and you should get a display similar to Figure 2.

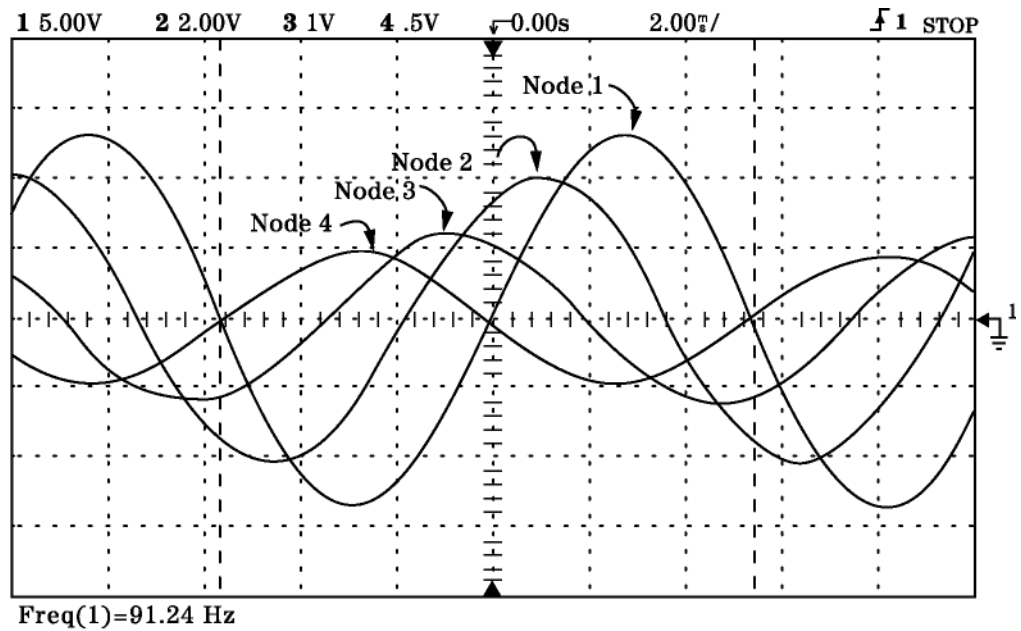

Figure 1 Voltages at Four Points in Phase-Shift Oscillator RC Network

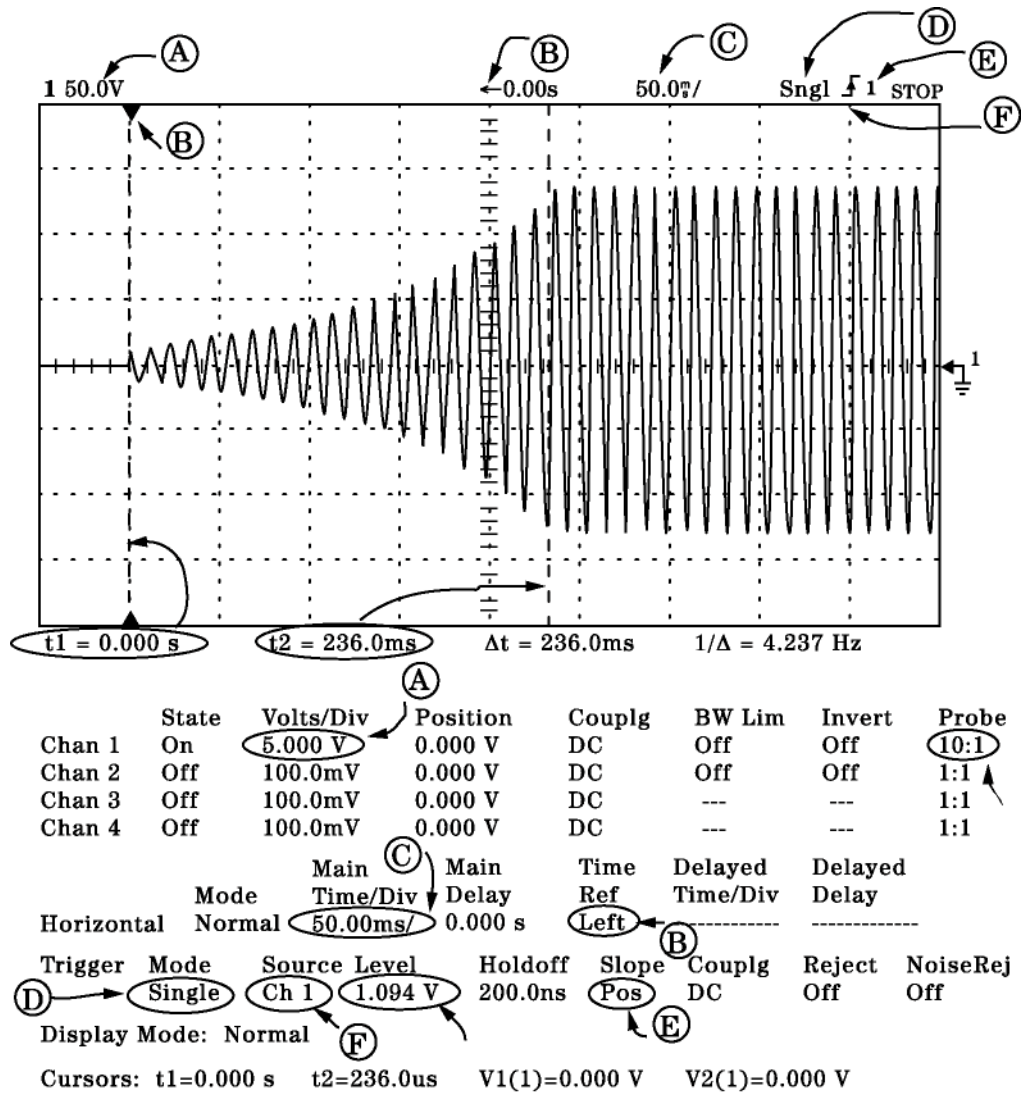

Figure 2 - Start-up of RC Phase-Shift Oscillator